

## MESSIAH 2 No-Swap Mod v7/v8 Install Diagrams (at your own risk)

v1.3 15-Feb-03 by Charlie\_ps2

### CONTENTS

[Disassembly](#)

[Soldering Notes](#)

[Messiah 2 Installation](#)

[REASSEMBLY](#)

[Using the Messiah 2](#)

[NTSC/PAL Colour Fix](#)

[Troubleshooting](#)

[Disclaimer](#)

**Amended to:**

1. Cater for GH-017 power (3.45v)
2. Changing the recommended CLK point
3. Add information to the Troubleshooting section
4. Update diagrams in line with the above

### **DISASSEMBLY**

***Prior to disassembly, test the PS2 for both CD and DVD games. This should then be the first test to perform when the PS2 is re-assembled.***

You will need the following tools to accomplish the disassembly task

1. A Philips screwdriver for [Disassembly/Reassembly](#)
2. An optional pair of TWEEZERS (a TWEEZER) to manipulate the flat cables
3. Double-sided tape to hold detached objects and the Messiah 2 in a stable position

***Detailed disassembly instructions are provided in a separate document (split out for size reasons when posting on the forums).***

**Please note that disassembling the PS2 which requires removal of the warranty sticker renders void the manufacturer's warranty and by doing so you accept all associated risk.**

When you have disassembled your PS2, you are ready to commence installation of the modchip.

## SOLDERING NOTES

The recommended equipment needed for the soldering job is:

- a) 15-18 watt soldering iron for the solder work (not higher than 18 watt or damage could result)
- b) 25-35 watt soldering iron (450°C) for stripping enamelled copper wire\*\* (if you use that wire)
- c) 0.10 mm solder tip (this is very small)
- d) 35/36 swg wire (=32/33 awg) \*\* for all but 3.45v and GROUND
- e) 23 swg = 22 awg insulated stranded wire for 3.45v and GROUND
- f) Liquid Flux for assisting in the cleaning of target points
- g) Solder paste (a mixture of flux and solder) to assist soldering to lacquered points
- h) De-soldering braid
- i) A safety razor blade & Blue Tack (plastic dough) to hold the razor blade in place
- j) Double sided tape to fix the mod chip into final position

\*\* "Self-Stripping" (a misnomer), enamelled copper wire is recommended rather than sheathed as it requires less space and is easier to feed through to the other side of the motherboard.

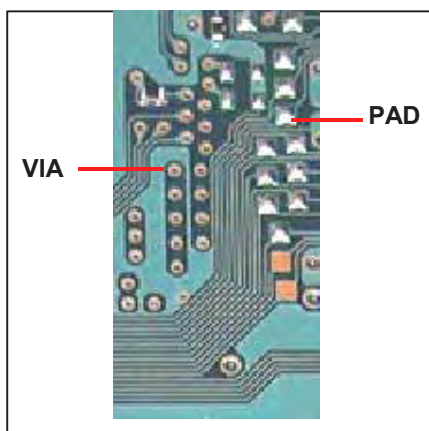

With reference to the picture on the left, it is straightforward to solder a wire to a **PAD**.

However soldering a wire to a **VIA** must be performed with great care since damage to a VIA can ruin the motherboard. If you solder to a VIA, you would strip and tin your wire, dip it in solder paste, spray the VIA with flux spray and touch solder the wire end for half a second to just above the end. This is sufficient for the solder paste to take the lacquer away from the VIA and bond the tinned end to the VIA. If you linger too long with the iron, the VIA will disappear into the motherboard layers and it's all over.

Generally, this is the soldering technique where the **small processor pins** are involved:

- Strip the solder end of the enamelled copper wire using the hot 25W iron.
- Dip the stripped end into the solder paste
- Squirt a small amount of flux spray onto the BIOS pins to assist adhesion of the solder
- Solder to the pin using the razor blade technique described below.

The **razor blade technique** is to place a single safety blade between the pin on which you are working and a neighbour. This protects the neighbour from bridging and splatter. With your **0.1mm tip** and 15W or 18W iron, work towards the blade (so as to avoid contaminating the other neighbour).

For the **Ground pads** a low wattage iron is somewhat challenged. The tip must be clean so that it is able to reach full temperature; the Ground pad should be scraped back to bare copper which should then be freshly tinned, as with the end of the Ground wire and heat then applied to the end of the wire touching the tinned pad.

**Wire layout is important.** The wires should be laid flat along the motherboard and exposed soldered ends should be kept short. **Hot glue** should be used to hold the wires down so that they are not compressed when the metal cover is put back; if they are compressed, there is a danger that the soldered ends will bow and thus short circuit.

## MESSIAH 2 INSTALLATION

There are 24 wires to solder and this is a **difficult, specialised job**. The Messiah 2 is small (the picture below is at c. 9x magnification). The official Messiah 2 web site (<http://messiah2.com/>) may be worth a visit for cross-reference. All of the Messiah 1 points are preserved (you can use 3.3v instead of 3.45v) and the only additional point is the clock **CLK** since the Messiah 2 carries no internal clock. The chip may appear 'upside down' in the picture but that is the recommended orientation for placement on the motherboard.

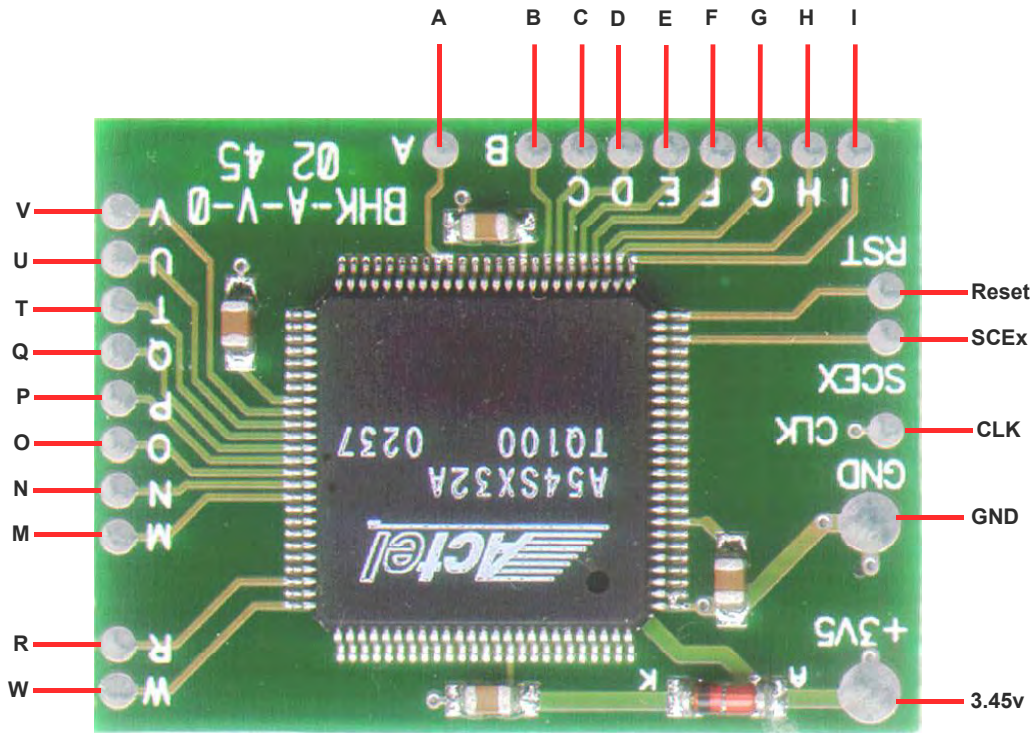

The schematics below show which PS2 motherboard chips are directly affected by the installation process together with their orientation on the motherboard. This covers points B, C, D, E, F, G, H, I on the CD/DVD Controller and Digital Signal processor; M, N, O, P, Q, R, T, U, V, W on the BIOS chip.

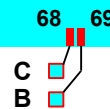
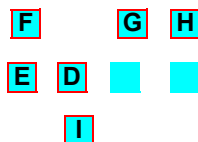
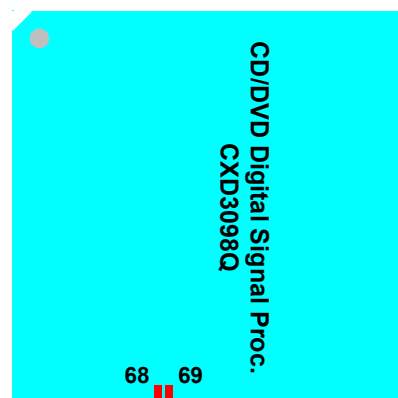
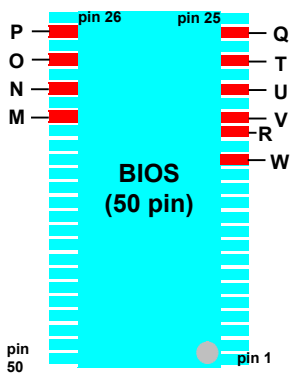

The **low resolution photographs** are for positional orientation (rather than magnification). The Messiah 2 mod is slim enough to be fixed onto the 'vacant' area on the PS2 motherboard (GH-019 & GH-022).

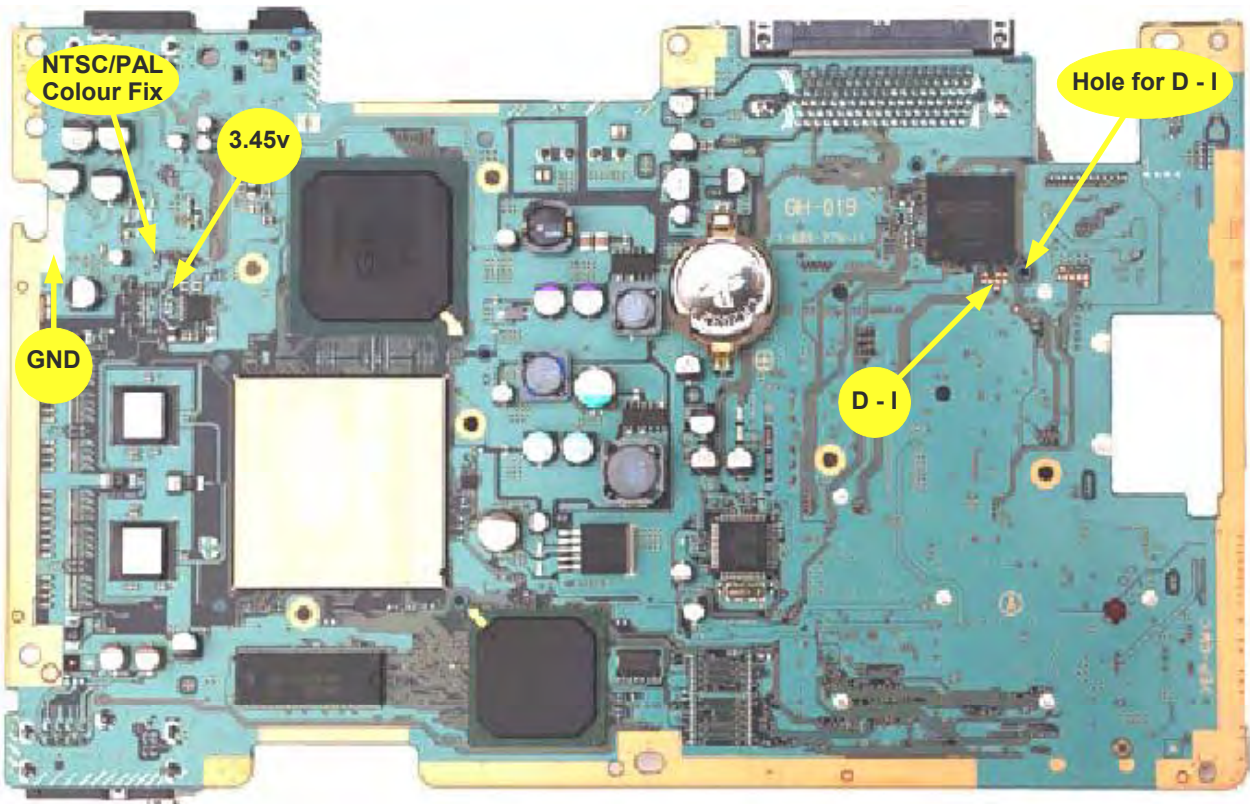
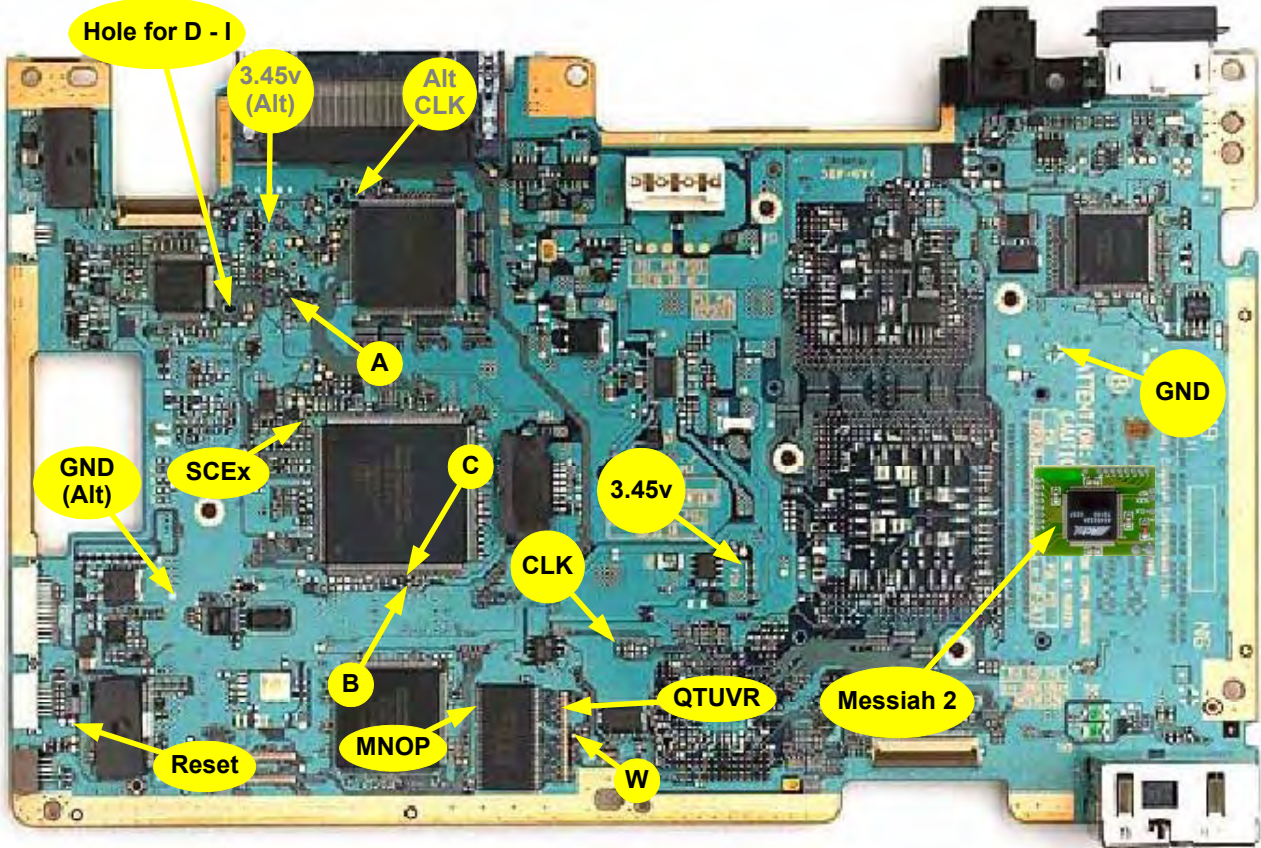

*It is recommended that you solder to the PS2 motherboard first and then connect each wire to the appropriate point on the Messiah 2.*

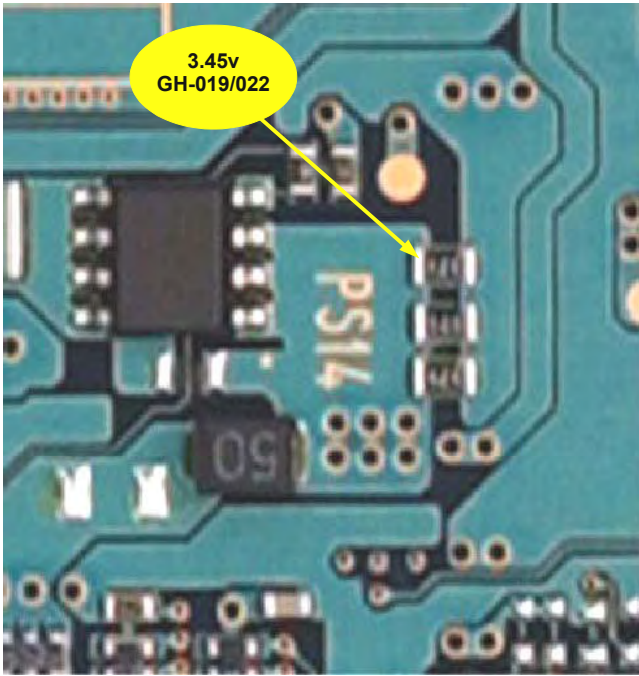

**Power (3.45v), Ground (GND), RESET and SCEX)**

Install these points first. Note that **3.45v** & **GND** are 23 or 25 swg = 22 or 24 awg insulated stranded cable.

The **GND** copper pads are covered with lacquer that must be scraped off or the lacquer removed with flux spray as described in the [soldering](#) section.

Alternate **GND** & **3.45v** points are illustrated for **GH-017** board and for Messiah 2 location on the outside of the metal cage (ex-Magic 2).

Care should be taken to ensure that the **SCEX** signal is properly soldered to its proper location on the resistor; the bond must be good (without damaging the resistor).

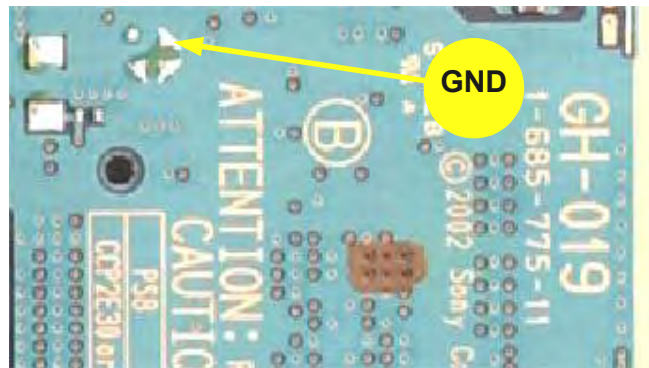
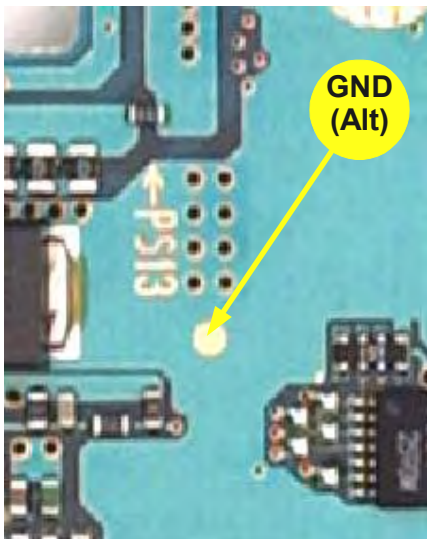

The **Alternate CLK** wire (see below) is not recommended because of the distance involved laying the wire over the motherboard to the Messiah 2. However, past editions of this document have specified this point and on v7 PS2s has not proved to be problematic. The recommended **CLK** point is on **Page 7**.

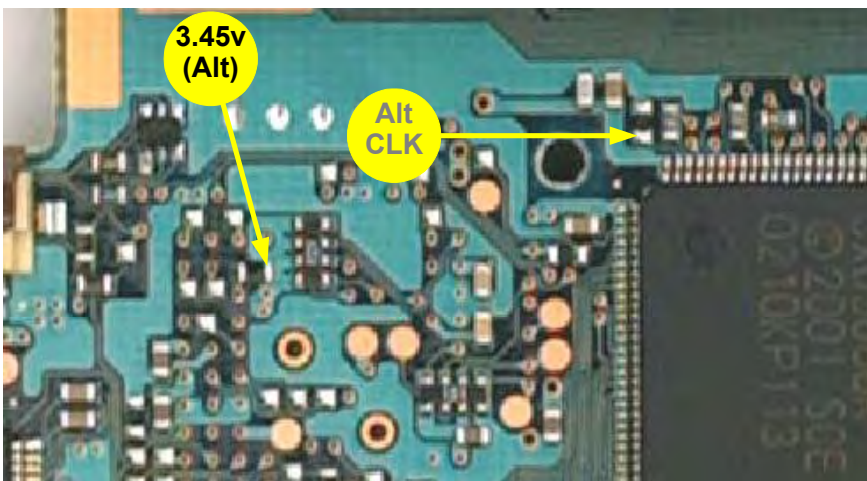

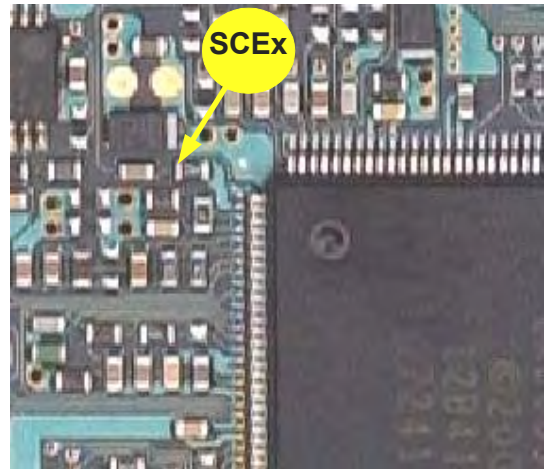
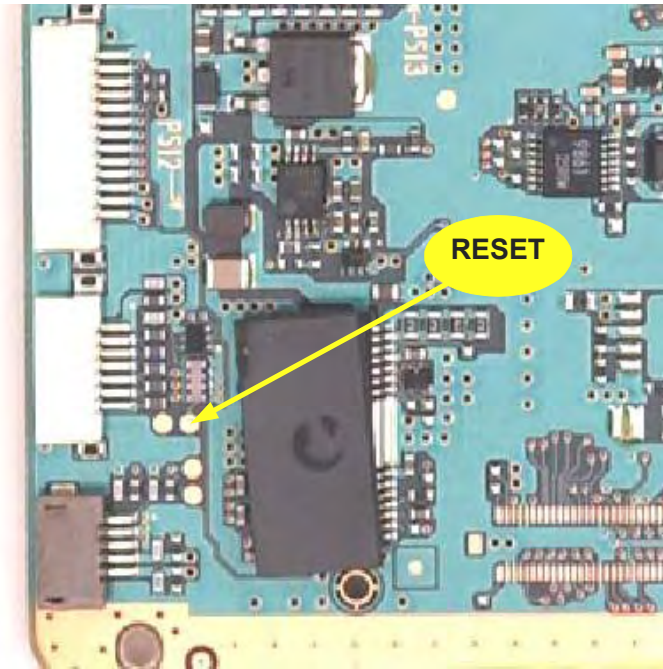

Now connect the **B** and **C** wires as per the photograph to the right and the **A** wire as per the photograph below. (**SCEx** is shown for positional reference).

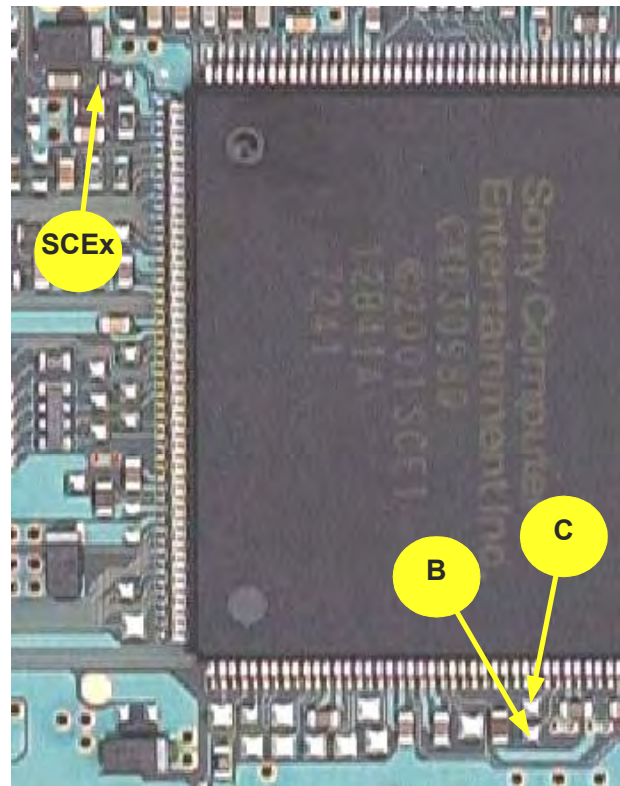
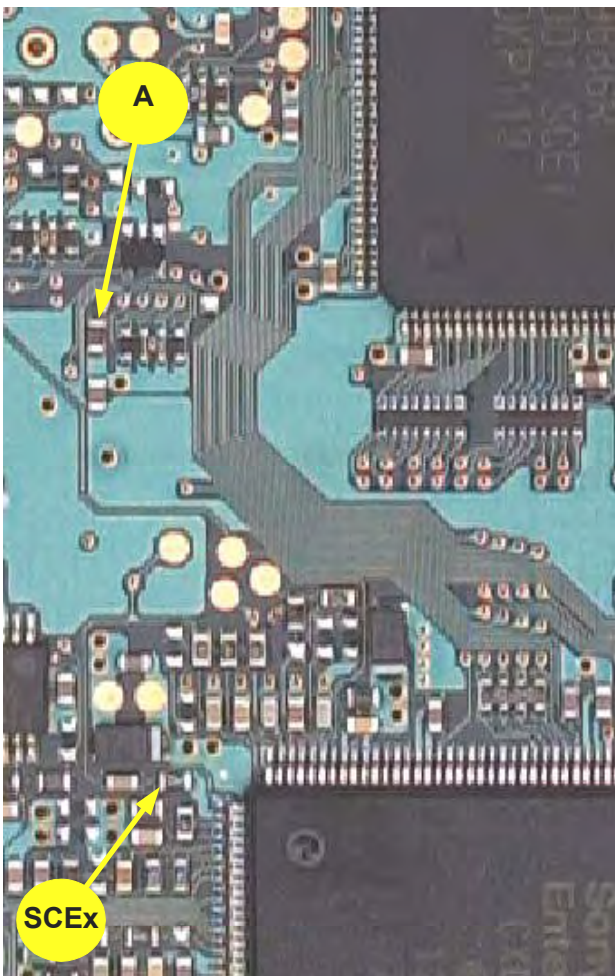

You will need to solder the **CLK** wire and the wires to the BIOS chip (points **MNOP QRTUVW**).

The BIOS pins are very close together; so you should take one safety razor blade (or Exacto blade) and some blue-tack (plastic dough) into which you would bed the blade. The blade would be placed between the pins to prevent solder from bridging to the adjacent pins. You would work towards the blade.

Note that there is very little available solder on each pin and you should be skilled in [soldering techniques](#) to ensure a good bond.

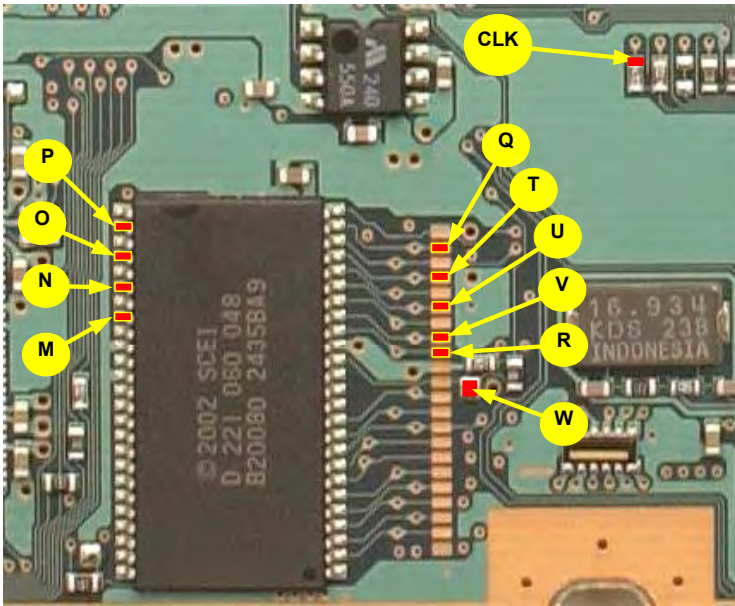

The **CLK** point needs to be carefully wired back to the Messiah 2. The wire should be laid along a ground plane – namely flat along the motherboard without traversing any surface mounted components.

BIOS points **QRTUVW** should be soldered first followed by **MNOP** which should traverse the BIOS chip and be secured to the top of the chip with Epoxy glue (lower photograph – please note this was taken before **W** was connected).

The **GAP BIOS** is wired in the same way – i.e. ignore the gap.

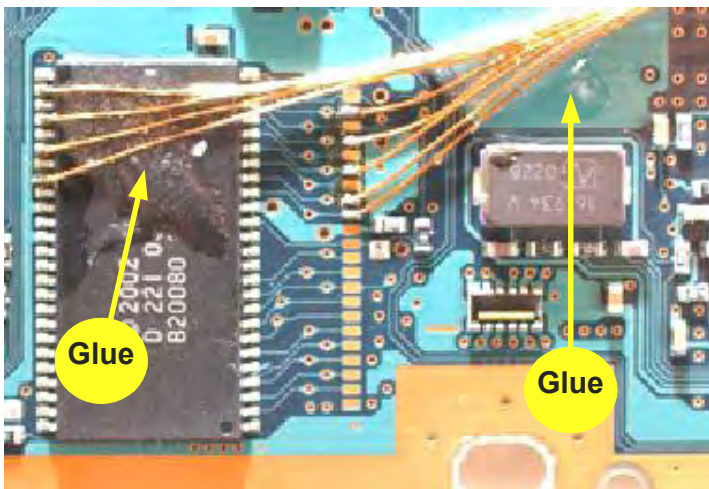

This completes wiring to the “top” side of the PS2 motherboard.

Note the position on the PS2 motherboard topside of the hole through which wires **DEFGHI** are to pass. (See picture to the right). Ensure you have enough wire length to run from the CD/DVD Controller pads on the underside, through the hole to the Messiah 2 chip. You are advised to solder to the pads first, and then pass the wires through the hole.

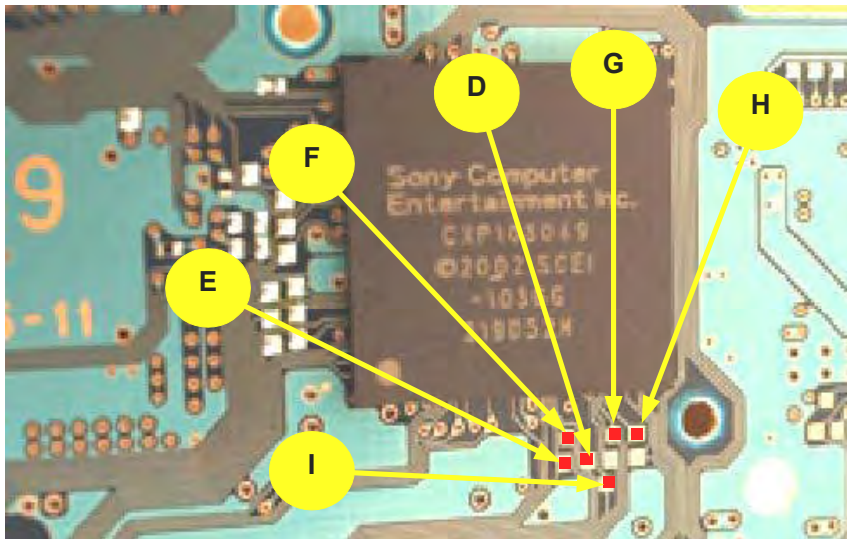
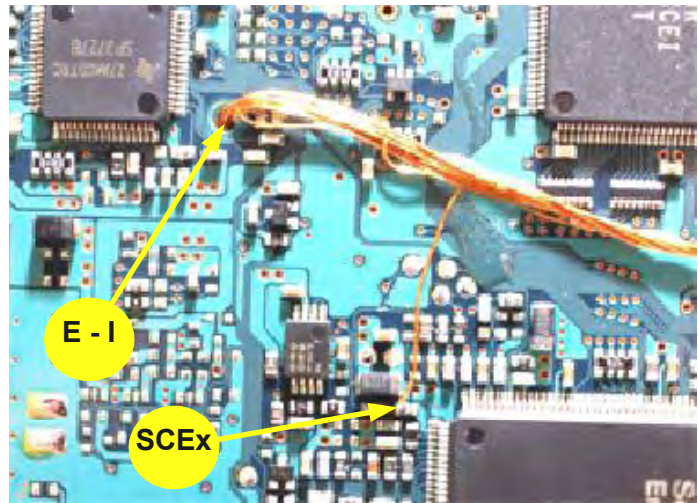

Turn the PS2 motherboard over. Locate the PS2 CD/DVD Controller pads (with reference to the [schematic](#) if necessary). Solder **DEFGHI** to the pads illustrated in the picture to the left.

You may care to place a sticky identification label onto each wire to ensure that it is subsequently correctly connected to the Messiah 2. Alternatively, connect each wire in turn to the Messiah 2; this will ensure you don't cross-connect any wires.

When this is done, **Messiah 2 wiring to the motherboard is complete** and the connexions can be made to the Messiah 2 with reference to the [Messiah/Clone Schematic](#).

If you wish, and while you are on that side of the motherboard, you may also implement the **NTSC/PAL COLOUR FIX** as documented below.

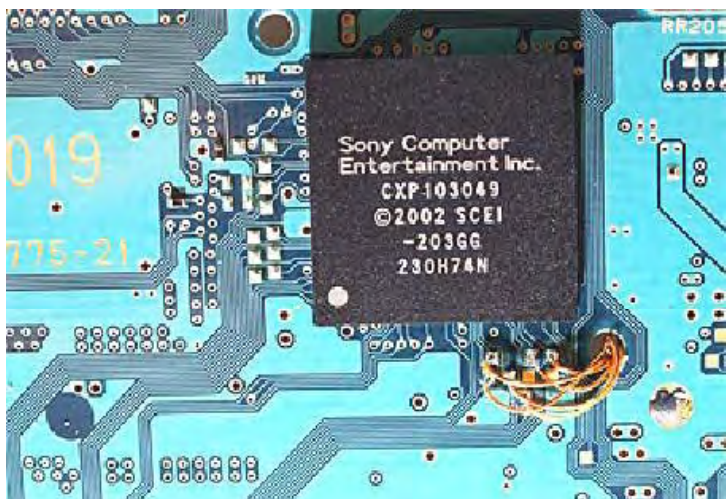

## NTSC/PAL COLOUR FIX (& 3.45v for GH-017 Board)

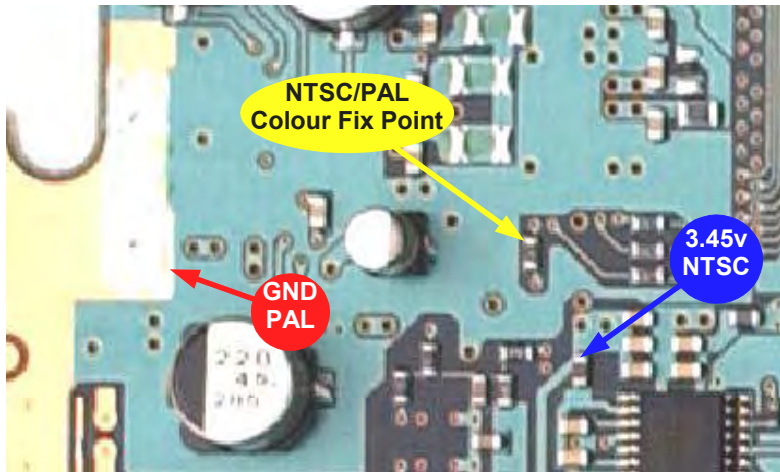

**NTSC** motherboards would require the *Colour Fix point* to be taken to **3.45v**. It forces NTSC colour on all output. All **PAL** games will then be put out in **NTSC** colour mode and all PS1 games will display proper **NTSC** colour. The frame rate for **PAL** games will remain at 50 Hz.

**PAL** motherboards would require the *Colour Fix point* to be taken to **GND**. All **NTSC** games will then be put out in **PAL** colour mode. The frame rate for all **NTSC** games will remain at 60 Hz.

This fix has the advantage of ensuring that games from any region play in the selected colour mode provided that the TV will support the original frame rate.

**Please note that GH-017 motherboards do not have the 3.45v point shown on page 5 (they do have the alternate point shown). The NTSC 3.45v point may be used instead if preferred.**

## REASSEMBLY

Reassembly is essentially the reverse of disassembly. These steps are:

1. Carefully place the PS2 motherboard onto the bottom casing ensuring that everything sits square. Take care that no damage occurs to the memory card/controller cable (which should have been taped down).
2. Reattach the memory card/controller flat cable to the PS2 motherboard and refasten its securing clip.
3. Seat the memory card/controller back into position and re-insert the two brass screws to fasten the PS2 to its lower casing. The locator pins for the memory card/controller go into the middle locating holes.
4. Reattach the disk drive cables to the PS2 motherboard.
5. Insert the RESET/EJECT switch back into the upper casing. This might be tricky on first attempt. Put the switch flat in correct orientation against the underside of the upper casing. Push it toward the holes through which the buttons emerge keeping the switch parallel with the short side of the casing. When a resistance is felt to the push, slide the buttons into the holes at whatever angle is necessary. Once the buttons are located in the holes, the switch should have moved forward slightly and be properly seated in its housing. **Take great care to ensure that the flat ribbon cable is not snagged or damaged.**
6. Now put the top back onto the PS2 (again taking care not to snag or damage the flat ribbon cable).
7. Turn the PS2 upside down and re-insert to casing screws.

## **USING THE MESSIAH 2**

### **BOOTING PS2 ORIGINALS (CD or DVD, DVD9 ALL REGIONS)**

- Switch on the PS2 to STANDBY (red light) and press EJECT to open the disk tray
- Insert the game into the disk tray and press EJECT or RESET to close the tray & boot the game

### **BOOTING PS2 BACKUPS (CD-R or DVD-R ALL REGIONS)**

- Switch on the PS2 to STANDBY (red light) and press EJECT to open the disk tray
- Insert the game into the disk tray and press EJECT or RESET to close the tray & boot the game

### **BOOTING PS1 GAMES (CD or CD-R ALL REGIONS)**

- Assuming the PS1 disk to be in the disk tray, put the PS2 into STANDBY mode (red light)
- Hold RESET (until the blue EJECT light comes on) then release RESET. The game will boot.

### **PLAYING LOCAL REGION DVD MOVIES**

- Insert the DVD movie into the disk tray and put the PS2 to STANDBY (red light)
- Hold RESET (until the blue EJECT light comes on) then release RESET.
- If the Browser appears, select the gold disk and press X to complete the movie load.
- Alternatively hold RESET for 5 seconds to turn the Messiah 2 off.

### **PLAYING OUT-OF-REGION DVD MOVIES (Needs AR2/v2 or GS 2/v2 or DVD Region X)**

- Insert AR2/v2, GS2/v2 or DVDRX into the disk tray and close the tray
- Hold RESET (until the blue EJECT light comes on) and then release to boot AR2/GS2/DVDRX
- Alternatively hold RESET for 5 seconds to turn the Messiah 2 off.
- At the menu, select DVD MOVIE PLAYER and press X on the controller
- The disk tray will eject; remove AR2/GS2/DVRX and put the out-of-region movie into the tray
- Press EJECT to close the tray and wait for a few seconds
- When/if the Browser appears, select the gold disk and press X to complete the boot

### **DISABLING THE MESSIAH 2 (e.g. PS1 anti-mod protected game)**

- Insert the relevant game into the disk tray and put the PS2 to STANDBY (red light)
- Hold RESET for 5 seconds beyond the moment when the blue EJECT lamp comes on
- The game will then boot according to standard PS2 rules for the region concerned
- The Messiah 2 is disabled until it has been put back to STANDBY and booted normally

## TROUBLESHOOTING (no guarantees)

### **Tools needed**

To diagnose a mis-install, you will need an 8x magnifying glass to identify bridged pins or small solder splays. A multi-meter helps also to check continuity between pin and pad on the Messiah 2. Sometimes the lacquer hasn't been adequately removed (esp. SCEX) so a continuity check helps.

### **PS1 backups won't boot**

Suspect **SCEX** in the first instance. Remember that the PS2 components are lacquered and a good electrical connexion is necessary. It is also important to note that if too much heat is applied during soldering to the point where **SCEX** is located might have damaged that component. Otherwise suspect that you haven't put the Messiah 2 into PS1 mode.

### **PS2 backups/imports won't boot or Red Screen Displays**

In this scenario, the disk has been seen (the groove is found and focus established) but the PS2 has been unable to identify it as a valid disk type (Audio/DVD/PS1/PS2).

Check all soldering for bridges or balls lying beneath or behind the BIOS legs. Difficult to spot.

If it's all backups that won't boot, then try cleaning the laser lens with a cleaning CD. If it's just DVD-Rs that won't boot, suspect wire **E**, wire **W** or the DVD laser diode (which may need recalibration). Laser Azimuth might also need adjusting.

Then suspect solder bridges. If you can't see bridges, then it's the hard way. If the BIOS wires are attached, detach them from the BIOS and clean up. Then boot a backup using AR2/GS2. If it works, **A-I** are OK and the BIOS was the problem. (You can try this with the BIOS wires still attached but if it doesn't work, you'll have to take the BIOS wires off).

When you can boot backups (including DVD-R) with AR2/GS2, then carefully re-attach the BIOS wires, **MNOP QRTUVW**. Then try direct booting of backups and/or imports.

### **'Disc Reading' on Browser Screen or clicking sounds**

The disk is seen (groove is found & focus established); the PS2 has identified it as a valid disk type (Audio/DVD/PS1/PS2) but cannot do anything more with the disk or takes ages to load. This is most likely a laser related issue (clean the lens and/or the disk). Or adjust the laser.

If the drive seems to load sluggishly (like it seems not to have enough power), the Messiah 2 might be grounding on the metal cage when it is closed. Use thinner double sided tape!

### **Screen remains black**

Assuming that the electrons were whirling initially, then this is usually a mis-install on the BIOS.

If the electrons never happened, then some ribbon cables may have snagged when you put the PS2 back together. Or the pressure on wires that have been laid "in space" has caused the soldered ends to touch; the solution in this case is to lay the wires flat and hot glue them to fix.

Possibly a fuse has blown (one of those little square chips with a number on them).

If you have a memory card inserted, try removing it. Some people have had black screen issues when their memory card was inserted (see below).

### **DVD Movies are choppy**

Suspect the media or laser condition. No Messiah 2 condition is likely to arise in this regard.

### **DVD Movies don't boot**

Check your boot method. If booting an import movie with GS2/AR2, remember to boot GS2/AR2 with the PS1 method above (or with Messiah 2 switched off) so as to bypass what the Messiah 2 would otherwise do for PS2 games.

### CD/CD-R games boot but not DVD/DVD-R

It is likely that one of the following causes applies:

- The **W** wire or the **R** may be incorrectly connected.
- The laser lens is dirty and should be cleaned with a cleaning disk or a cotton swab. A lens can easily collect dirt if the PS2 is played horizontally. The DVD is read at a higher frequency than a CD and results are more sensitive to a dirty lens.
- The laser needs re-calibrating because of wear and tear. This is a complex process and should be carried out by a competent engineer. Pot resistance should not be lowered by more than 10% otherwise there is risk of the DVD laser diode overheating and giving out.
- The laser needs replacement because of severe wear and tear. This is more likely on older PS2s especially if they have been used extensively to play DVDs or have been regularly used with a NEO2.2 mod chip and the DVD-R boot method.

### The PS2 disk tray won't open when EJECT is pressed at power on

If the lights are on but you can't open the tray, then the Messiah 2 installation is likely to be incorrect and most likely the connexions to the **BIOS** chip.

### Messiah 2 won't boot if Memory Card is in

... but you can re-insert the memory card after booting. This might be accompanied by a loss of controller vibration. Please examine fuse at **PS7** marked with the legend **S7**.

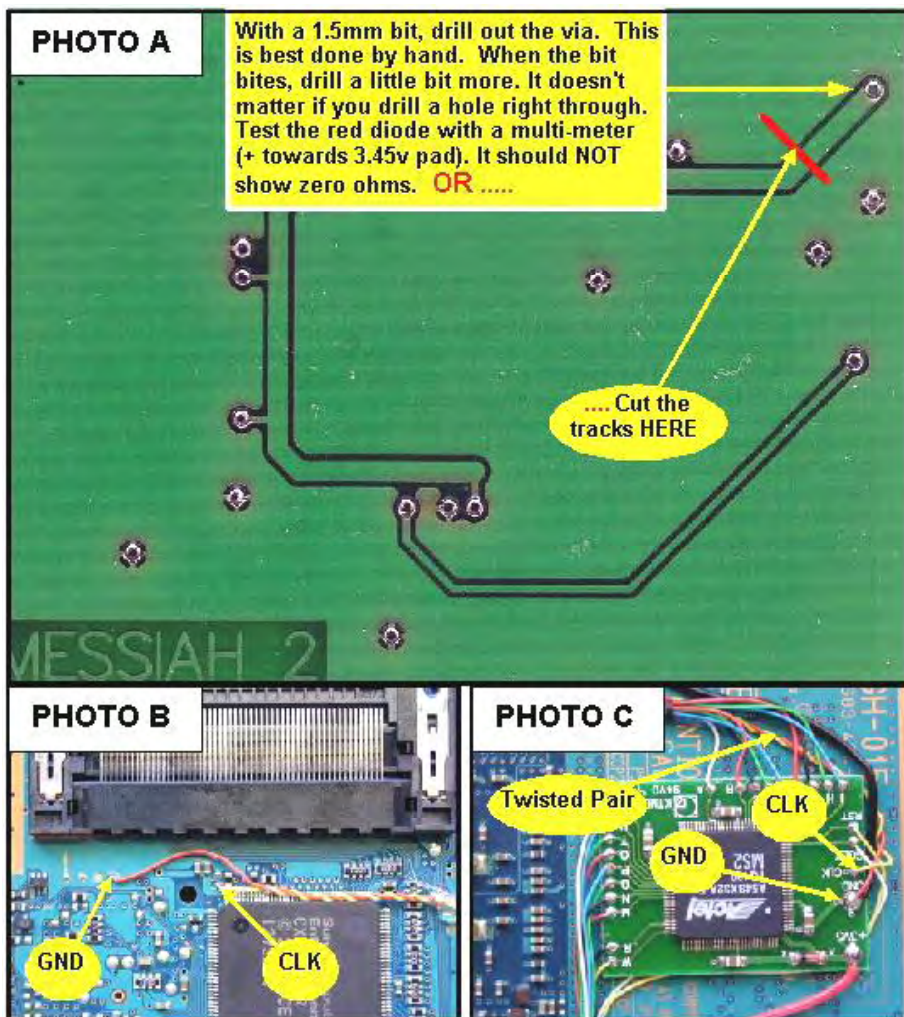

### ***Messiah 2 appears dead (pcb fault)***

If you are certain that your install is good yet the Messiah 2 appears dead, then you might have a Messiah 2 from the Actel batch 245 (or earlier); the Messiah 2 pcs have an error whereby a diode that regulates input voltage for the Actel chip is shorted and thus ineffective. Some Actel chip batches (particularly 245 written on the chip) work tightly within a spec 2.6v to 3.0v - Messiah 2 will not function.

The required fix is to be found at cut a track or drill out a via as shown in the photograph **A** on the previous page.

### ***Sound is tinny or odd or fails***

This problem has manifest itself on v5/v6 PS2s – but in theory it could happen in any case. Basically what is happening is that the wire carrying the 36MHz. clock to the Messiah 2 is inducing noise in other circuits. A long CLK wire at frequencies above 20MHz acts as it own capacitor which also degrades the clock. This is resolved by ensuring that there is a proper ground plane along the length of the clock wire.

The alternative ways of dealing with this in order of priority are:

1. Lay the **CLK** wire flat along the motherboard not crossing over any components.
2. Wire the **CLK** signal as a twisted pair, with the other wire being grounded at both ends (photographs **B & C**).
3. Use thicker wire (24 awg/25 swg) but lay it flat.

### ***If all else fails and it still doesn't work ...***

Back out of your installation, get the PS2 under control into "normal condition" and begin again. Perhaps consider obtaining professional assistance.

## **DISCLAIMER**

**The author of this document can accept no responsibility nor liability for the outcome of any work performed in conjunction with the contents of this document. Any such work carried out on a Playstation2 is at the risk of the person using this material. The material is essentially accurate and has been used to guide installation of the Messiah 2 device on both a v7 PAL Playstation2 (39002/3/4) and it's US equivalent (39001); however the skills of the installer are a key factor in enabling a successful outcome in the same way as the quality of media and burners used to make backups affects game loading/playing characteristics.**

**You are reminded that it is illegal to make pirate copies of software and it is not the intention of the author that you should make pirate copies of PS2 games.**

END.