

CONTENTS

[Disassembly](#)

[Soldering Notes](#)

[Messiah 2 Installation](#)

[NTSC/PAL Colour Fix](#)

REASSEMBLY

[Using the Messiah 2](#)

[Troubleshooting](#)

[Disclaimer](#)

Amended to:

- 1. Display the correct Messiah 2 image**
- 2. Add information to the Troubleshooting section**
- 3. Simplifies the NTSC/PAL Colour Fix advice**
- 4. Update diagrams in line with the above**
- 5. Correct Messiah 2 usage instructions**

DISASSEMBLY

Prior to disassembly, test the PS2 for both CD and DVD games. This should then be the first test to perform when the PS2 is re-assembled.

Please note that disassembling the PS2 which requires removal of the warranty sticker renders void the manufacturer's warranty and by doing so you accept all associated risk.

When you have disassembled your PS2, you are ready to commence installation of the modchip.

SOLDERING NOTES

The recommended equipment needed for the soldering job is:

- a) 15 watt soldering iron for the solder work (not higher than 18 watt or damage could result)
- b) 25-35w watt soldering iron (450°C) for stripping enamelled copper wire** (if you use this wire)
- c) 0.10 mm solder tip (this is very small)
- d) 34 or 35 swg wire (=31 or 32 awg) ** for all but 3.3v, 5v and GROUND
- e) 21 swg = 22 awg insulated wire for 3.3v, 5v and GROUND
- f) Liquid Flux for assisting in the cleaning of target points
- g) Solder paste (a mixture of flux and solder) to assist soldering to lacquered points
- h) De-solder braid
- i) A safety razor blade & Blue Tack to hold the blade in place
- j) Double sided tape to fix the mod chip into final position

** "Self-Stripping" (a misnomer), enamelled copper wire is recommended rather than sheathed as it requires less space and is easier to feed through to the other side of the motherboard.

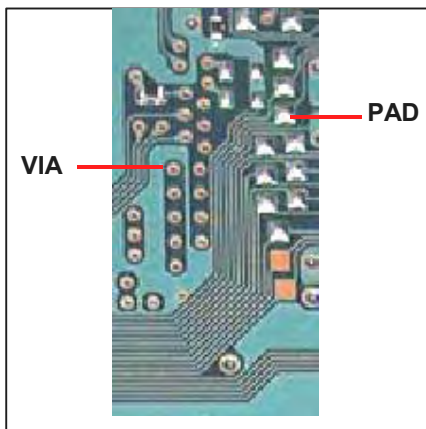

With reference to the picture on the left, it is straightforward to solder a wire to a **PAD**.

However soldering a wire to a **VIA** must be performed with great care since damage to a VIA can ruin the motherboard. If you solder to a VIA, you would strip and tin your wire, dip it in solder paste, spray the VIA with flux spray and touch solder the wire end for half a second to just above the end. This is sufficient for the solder paste to take the lacquer away from the VIA and bond the tinned end to the VIA. If you linger too long with the iron, the VIA will disappear into the motherboard layers and it's all over.

Generally, this is the soldering technique where the **small processor pins** are involved:

- Strip the solder end of the enamelled copper wire using the hot 25W iron.
- Dip the stripped end into the solder paste
- Squirt a small amount of flux spray onto the BIOS pins to assist adhesion of the solder
- Solder to the pin using the razor blade technique described below.

The **razor blade technique** is to place a single safety blade between the pin on which you are working and a neighbour. This protects the neighbour from bridging and splatter. With your 0.1mm tip and 15W iron, work towards the blade (so as to avoid contaminating the other neighbour).

For the **Ground pads** a low wattage iron is challenged. The tip must be clean so that it is able to reach full temperature; the Ground pad should be scraped back to bare copper which should then be freshly tinned, as with the end of the Ground wire and heat then applied to the end of the wire touching the tinned pad.

MESSIAH/CLONE INSTALLATION

There are 24 wires to solder and this is a specialised job. The Messiah/Clone is small (see the picture below). Before wiring the PS2, the Messiah/Clone should be prepared as described below.

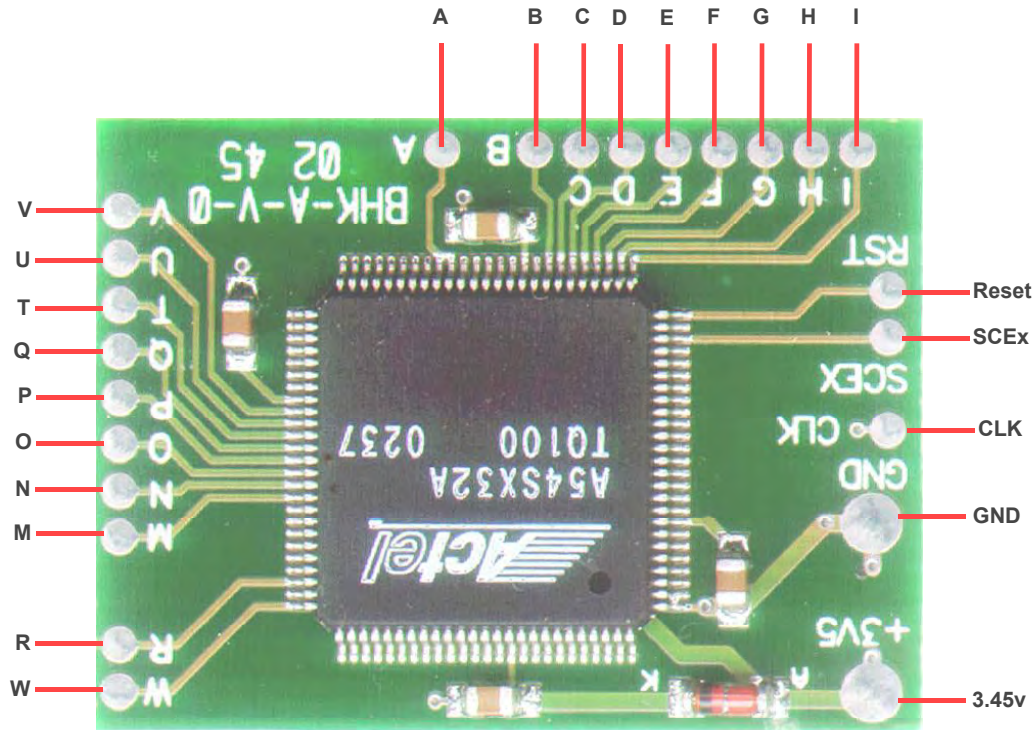

The schematics below show which PS2 motherboard chips are affected by the installation process.

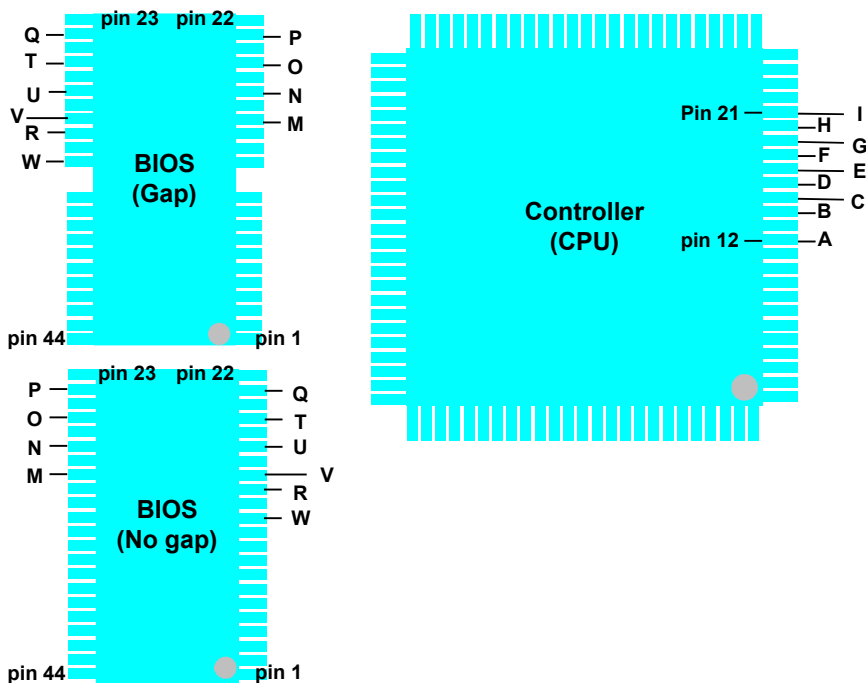

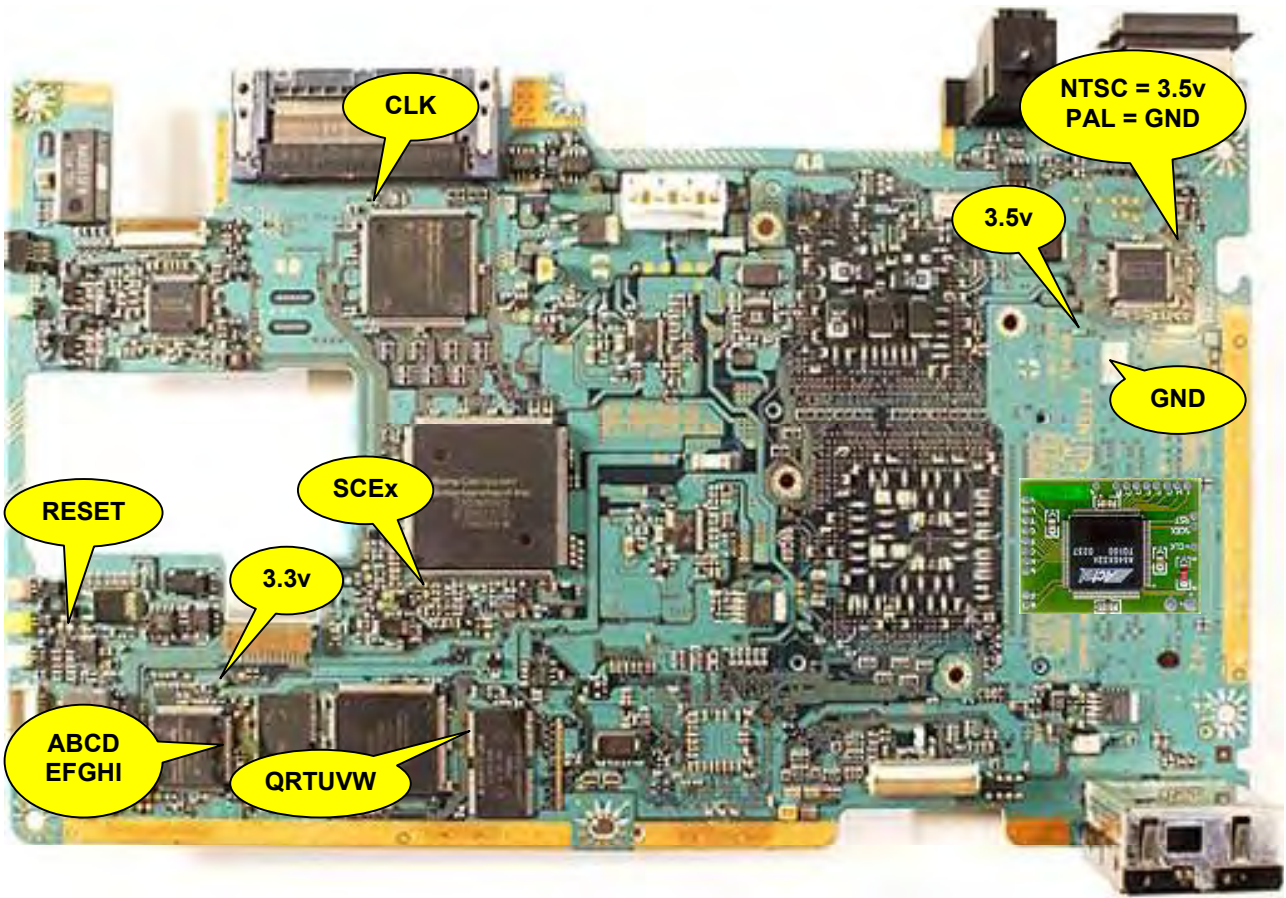

With reference to the above photo, solder wires to the **3.3v** and **GND** points. It is good practice to use thicker wire for power and ground and, of course, to insulate it.

To prepare the Ground point, scratch the indicated area clean so that it can be soldered onto. There are plenty of **GND** points that can be verified by continuity meter using the copper edging as reference point.

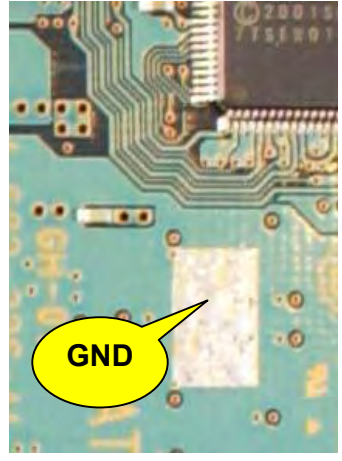
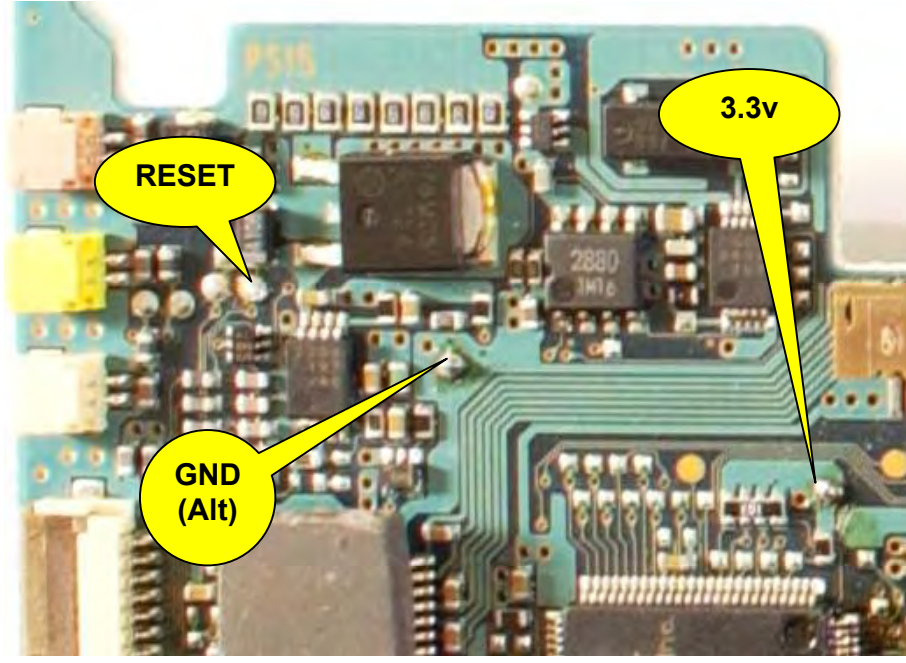

You should also solder the **RESET** and **SCEX** wires onto the indicated points using 31 or 32 awg (34 or 35 swg) wire. Likewise the **CLK** wire.

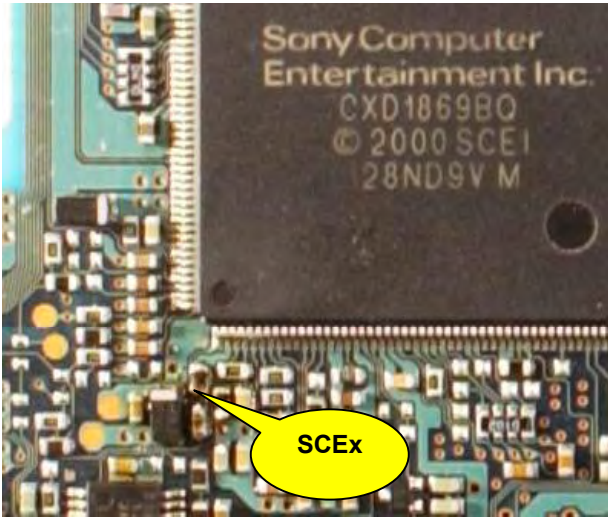

Note please that the **SCEx** point is at a specific end of a resistor (see photo to the left).

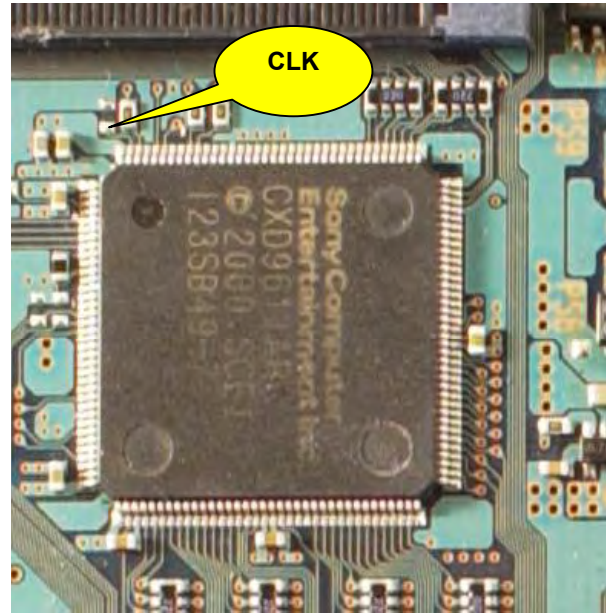

The **CLK** point is a pad above and to the left of pin 143 (see photo right). The **CLK** wire should be laid along the PS2 motherboard rather than allowed to run "in air". This is to ensure a proper ground plane to preserve the fidelity of the 36 MHz. Clock.

With the "easy" points now connected on the PS2 motherboard, you will need to solder the wires to the BIOS chip (points **MNOP QTUVRW**) and to the CD/DVD Controller (points **ABCDEFGHI**).

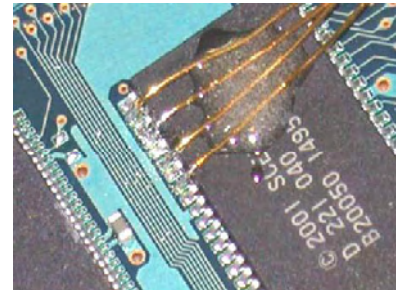
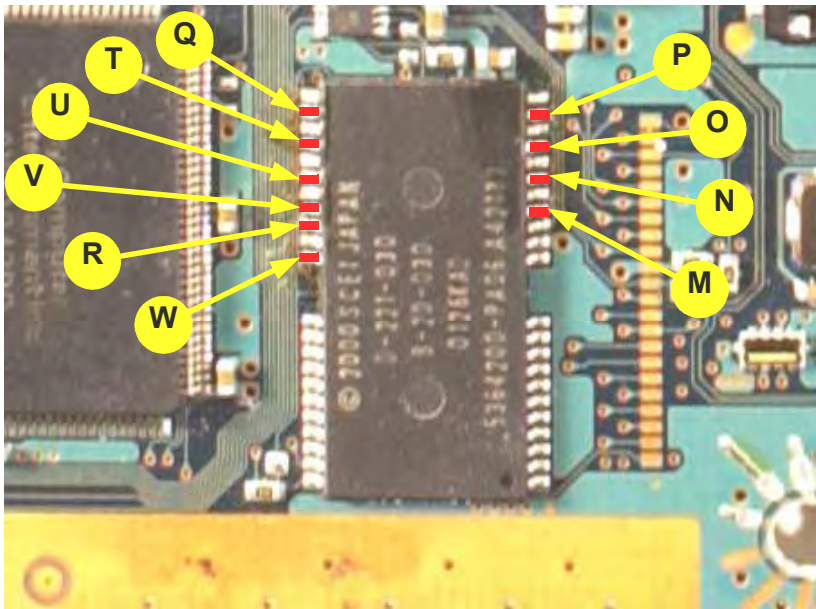

The BIOS pins are very close together; so you should use 32 awg (35 swg) wire. For best chance of avoiding solder bridges, you should take one safety razor blade (or Exacto blade) and some blue-tack (plastic dough) into which you would bed the blade. The blade would be placed between the pins to prevent solder from bridging to the adjacent pins. You would work towards the blade. In either order, points **QTUVRW** and **MNOP** should be soldered to their respective wires. Ideally the wires should traverse the BIOS chip and be secured to the top of the chip with Epoxy glue as illustrated in the small photograph below (reproduced from a v5 installation and is thus not identical).

Note that there is very little available solder on each pin and you should be skilled in [soldering techniques](#) to ensure a good bond.

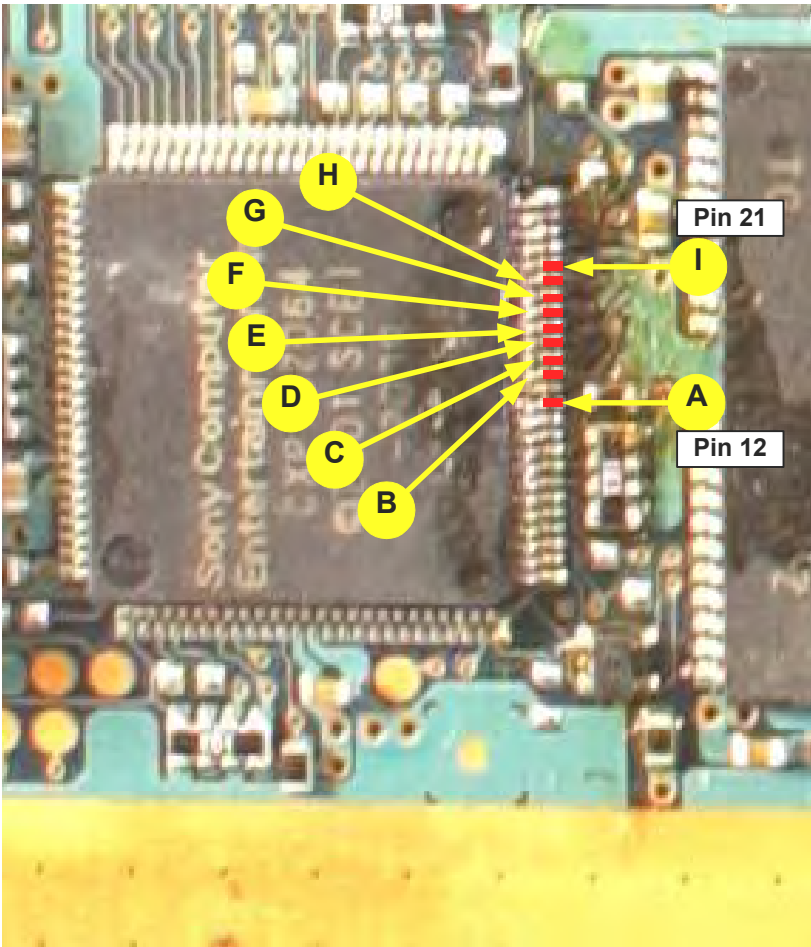

The **CD/DVD Controller** is even more difficult to solder than the BIOS.

With the exception of **A** the legs of the chip to which you are about to solder are less than 0.2mm apart. Magnifying optics are essential whether that be by way of two pairs of reading glasses or a magnifying stand.

Do this slowly and carefully making good use of the razor blade.

The Messiah can be fixed in either of the illustrated positions the PS2 motherboard with double-sided thin adhesive tape. Clocking at 4MHz, the Messiah will not overheat.

It is recommended that you solder to the PS2 motherboard first and then connect each wire to the appropriate point on the Messiah/Clone.

When the soldering to the motherboard is complete, connect each wire in turn to the Messiah/Clone taking great care not to misconnect any of them. Please refer to the [Pinouts diagram](#).

When the wires have been attached to the Messiah/Clone, ensure that the Messiah is taped to the PS2 motherboard using thin double sided tape affixed to the back of the Messiah 2.

With that done, installation is complete save for the optional (recommended) NTSC/PAL Colour Fix (see below)..

NTSC/PAL COLOUR FIX

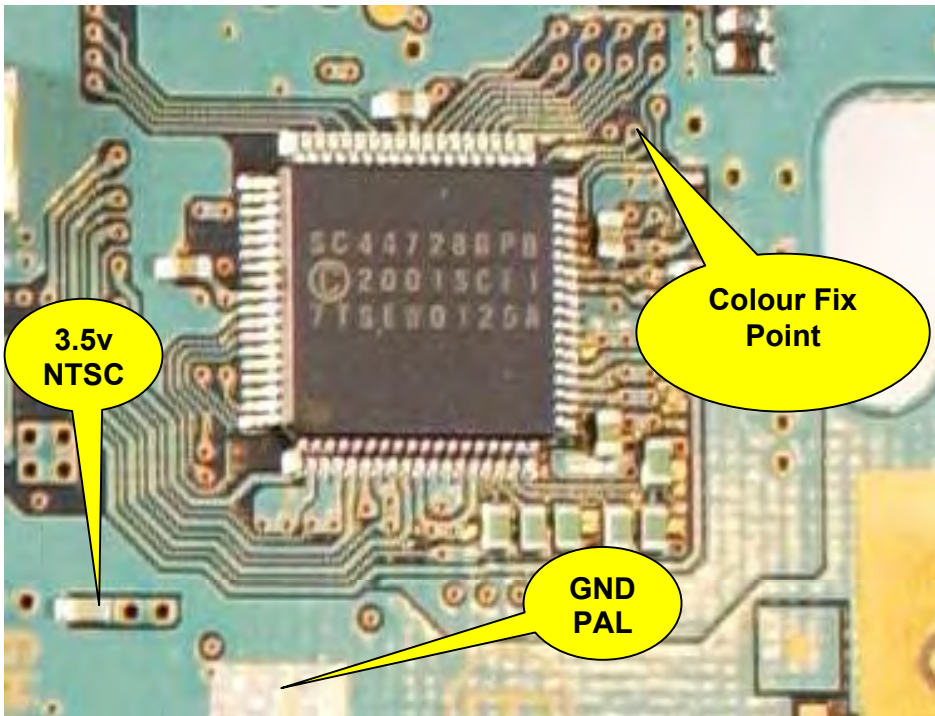

Note that the Colour Fix Point is a via. Take care.

NTSC motherboards would require the *Colour Fix point* to be taken to **3.3v**. It forces NTSC on all output. All **PAL** games will then be put out in NTSC and all PS1 games will display proper NTSC colour.

PAL motherboards would require the *Colour Fix point* to be taken to **GND**. All **NTSC** games will then be put out in **PAL**.

REASSEMBLY

Reassembly is essentially the reverse of disassembly. These steps are, principally:

1. Carefully place the PS2 motherboard onto the bottom casing ensuring that everything sits square. Take care that no damage occurs to the memory card/controller cable (which should have been taped down).
2. Reattach the memory card/controller flat cable to the PS2 motherboard and refasten its securing clip.
3. Seat the memory card/controller back into position and re-insert the two brass screws to fasten the PS2 to its lower casing. The locator pins for the memory card/controller go into the middle locating holes.
4. Reattach the disk drive cables to the PS2 motherboard.
5. Insert the RESET/EJECT switch back into the upper casing. This might be tricky on first attempt. Put the switch flat in correct orientation against the underside of the upper casing. Push it toward the holes through which the buttons emerge keeping the switch parallel with the short side of the casing. When a resistance is felt to the push, slide the buttons into the holes at whatever angle is necessary. Once the buttons are located in the holes, the switch should have moved forward slightly and be properly seated in its housing. **Take great care to ensure that the flat ribbon cable is not snagged or damaged.**
6. Now put the top back onto the PS2 (again taking care not to snag or damage the flat ribbon cable).
7. Turn the PS2 upside down and re-insert to casing screws.

USING THE MESSIAH 2

BOOTING PS2 ORIGINALS (CD or DVD, DVD9 ALL REGIONS)

- Switch on the PS2 to STANDBY (red light) and press EJECT to open the disk tray
- Insert the game into the disk tray and press EJECT or RESET to close the tray & boot the game

BOOTING PS2 BACKUPS (CD-R or DVD-R ALL REGIONS)

- Switch on the PS2 to STANDBY (red light) and press EJECT to open the disk tray
- Insert the game into the disk tray and press EJECT or RESET to close the tray & boot the game

BOOTING PS1 GAMES (CD or CD-R ALL REGIONS)

- Assuming the PS1 disk to be in the disk tray, put the PS2 into STANDBY mode (red light)
- Hold RESET (until the blue EJECT light comes on) then release RESET. The game will boot.

PLAYING LOCAL REGION DVD MOVIES

- Insert the DVD movie into the disk tray and put the PS2 to STANDBY (red light)
- Hold RESET (until the blue EJECT light comes on) then release RESET.
- If the Browser appears, select the gold disk and press X to complete the movie load.
- Alternatively hold RESET for 5 seconds to turn the Messiah 2 off.

PLAYING OUT-OF-REGION DVD MOVIES (Needs AR2/v2 or GS 2/v2 or DVD Region X)

- Insert AR2/v2, GS2/v2 or DVDRX into the disk tray and close the tray
- Hold RESET (until the blue EJECT light comes on) and then release to boot AR2/GS2/DVDRX
- Alternatively hold RESET for 5 seconds to turn the Messiah 2 off.
- At the menu, select DVD MOVIE PLAYER and press X on the controller
- The disk tray will eject; remove AR2/GS2/DVDRX and put the out-of-region movie into the tray
- Press EJECT to close the tray and wait for a few seconds
- Whe/ifn the Browser appears, select the gold disk and press X to complete the boot

DISABLING THE MESSIAH 2 (e.g. PS1 anti-mod protected game)

- Insert the relevant game into the disk tray and put the PS2 to STANDBY (red light)
- Hold RESET for 5 seconds beyond the moment when the blue EJECT lamp comes on
- The game will then boot according to standard PS2 rules for the region concerned
- The Messiah 2 is disabled until it has been put back to STANDBY and booted normally

TROUBLESHOOTING (no guarantees)

Tools needed

To diagnose a mis-install, you will need an 8x magnifying glass to identify bridged pins or small solder splays. A multi-meter helps also to check continuity between pin and pad on the Messiah 2. Sometimes the lacquer hasn't been adequately removed (esp. SCEX) so a continuity check helps.

PS1 backups won't boot

Suspect **SCEX** in the first instance. Remember that the PS2 components are lacquered and a good electrical connexion is necessary. It is also important to note that if too much heat is applied during soldering to the point where **SCEX** is located might have damaged that component. Otherwise suspect that you haven't put the Messiah 2 into PS1 mode.

PS2 backups/imports won't boot or Red Screen Displays

First suspect **SCEX** as per PS1 backups. If that's OK, then consider further.

In this scenario, the disk has been seen (the groove is found and focus established) but the PS2 has been unable to identify it as a valid disk type (Audio/DVD/PS1/PS2).

Check all soldering for bridges or balls lying beneath or behind the BIOS legs. Difficult to spot.

If it's all backups that won't boot, then try cleaning the laser lens with a cleaning CD. If it's just DVD-Rs that won't boot, suspect wire **E**, wire **W** or the DVD laser diode (which may need recalibration). Laser Azimuth might also need adjusting.

Then suspect solder bridges. If you can't see bridges, then it's the hard way. If the BIOS wires are attached, detach them from the BIOS and clean up. Then boot a backup using AR2/GS2. If it works, **A-I** are OK and the BIOS was the problem. (You can try this with the BIOS wires still attached but if it doesn't work, you'll have to take the BIOS wires off).

When you can boot backups (including DVD-R) with AR2/GS2, then carefully re-attach the BIOS wires, **MNOP QRTUVW**. Then try direct booting of backups and/or imports.

'Disc Reading' on Browser Screen or clicking sounds

The disk is seen (groove is found and focus established) and the PS2 has been able to identify it as a valid disk type (Audio/DVD/PS1/PS2) but cannot do anything more with the disk or takes ages to load.

This is most likely a laser related issue (clean the lens and/or the disk). Or recalibrate the laser.

If the drive seems to load sluggishly (like it seems not to have enough power which is not the case), particularly in **PS1 mode**, check wire **SCEX**.

Screen remains black

Assuming that the electrons were whirling initially, then this is usually a mis-install on the BIOS, often **MNOP**.

If the electrons never happened, then some wires likely snagged when you put the PS2 back together and possibly a fuse has blown (one of those little square chips with a number on them).

If you have a memory card inserted, try removing it. Some people have had black screen issues when their memory card was inserted (see below).

DVD Movies are choppy

Suspect the media or laser condition. No Messiah 2 condition is likely to arise in this regard.

DVD Movies don't boot

Check your boot method. If booting an import movie with GS2/AR2, remember to boot GS2/AR2 with the PS1 method above (or with Messiah 2 switched off) so as to bypass what the Messiah 2 would otherwise do for PS2 games.

CD/CD-R games boot but not DVD/DVD-R

It is likely that one of the following causes applies:

- The **W** wire or the **R** may be incorrectly connected.
- The laser lens is dirty and should be cleaned with a cleaning disk or a cotton swab. A lens can easily collect dirt if the PS2 is played horizontally. The DVD is read at a higher frequency than a CD and results are more sensitive to a dirty lens.
- The laser needs re-calibrating because of wear and tear. This is a complex process and should be carried out by a competent engineer. Pot resistance should not be lowered by more than 10% otherwise there is risk of the DVD laser diode overheating and giving out.
- The laser needs replacement because of severe wear and tear. This is more likely on older PS2s especially if they have been used extensively to play DVDs or have been regularly used with a NEO2.2 mod chip and the DVD-R boot method.

The PS2 disk tray won't open when EJECT is pressed at power on

If the lights are on but you can't open the tray, then the Messiah 2 installation is likely to be incorrect and most likely the connexions to the **BIOS** chip.

Messiah 2 won't boot if Memory Card is in

... but you can re-insert the memory card after booting. This might be accompanied by a loss of controller vibration. Please examine fuse at **PS7** marked with the legend **S7**.

Messiah 2 appears dead (pcb fault)

If you are certain that your install is good yet the Messiah 2 appears dead, then you might have a Messiah 2 from the Actel batch 245 (or earlier); the Messiah 2 pcbs have an error whereby a diode that regulates input voltage for the Actel chip is shorted and thus ineffective. Some Actel chip batches (particularly 245 written on the chip) work tightly within a spec 2.6v to 3.0v and hence the Messiah 2 will not function.

The required fix is to be found at cut a track or drill out a via as shown in the photograph.

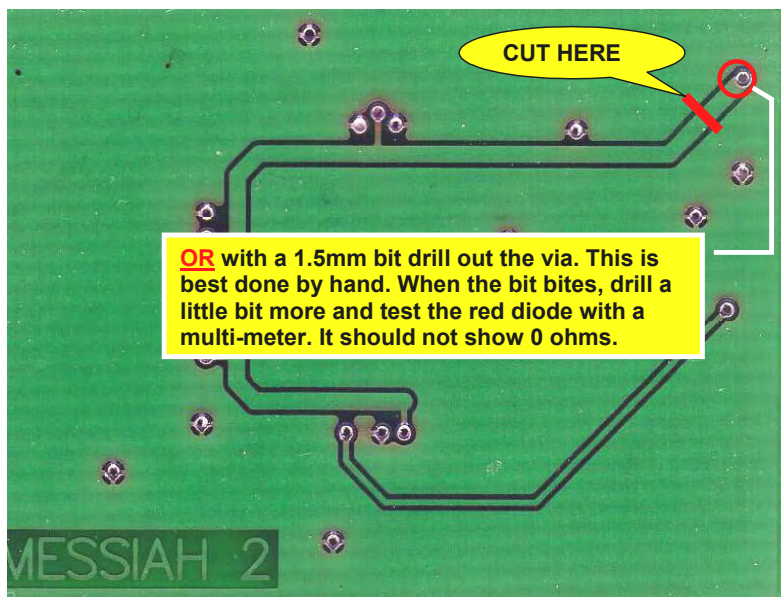

Sound is tinny or odd or fails

This problem has manifest itself on v5/v6 PS2s – but in theory it could happen in any case. Basically what is happening is that the wire carrying the 36MHz. clock to the Messiah 2 is inducing noise in other circuits. A long CLK wire at frequencies above 20MHz acts as it own capacitor which also degrades the clock. This is resolved by ensuring that there is a proper ground plane along the length of the clock wire.

The alternative ways of dealing with this in order of priority are:

1. Lay the **CLK** wire flat along the motherboard not crossing over any components.
2. Wire the **CLK** signal as a twisted pair, with the other wire being grounded at both ends.
3. Use thicker wire (24 awg/25 swg) but lay it flat.

If all else fails and it still doesn't work ...

Back out of your installation, get the PS2 under control into "normal condition" and begin again. Perhaps consider obtaining professional assistance.

DISCLAIMER

The author of this document can accept no responsibility nor liability for the outcome of any work performed in conjunction with the contents of this document. Any such work carried out on a Playstation2 is at the risk of the person using this material. The material is essentially accurate and has been used to guide installation of the Messiah 2 device on both a v7 PAL Playstation2 (39002/3/4) and it's US equivalent (39001); however the skills of the installer are a key factor in enabling a successful outcome in the same way as the quality of media and burners used to make backups affects game loading/playing characteristics.

You are reminded that it is illegal to make pirate copies of software and it is not the intention of the author that you should make pirate copies of PS2 games.

END.